

PGS Family

Plane Grating Spectrometer
from ZEISS

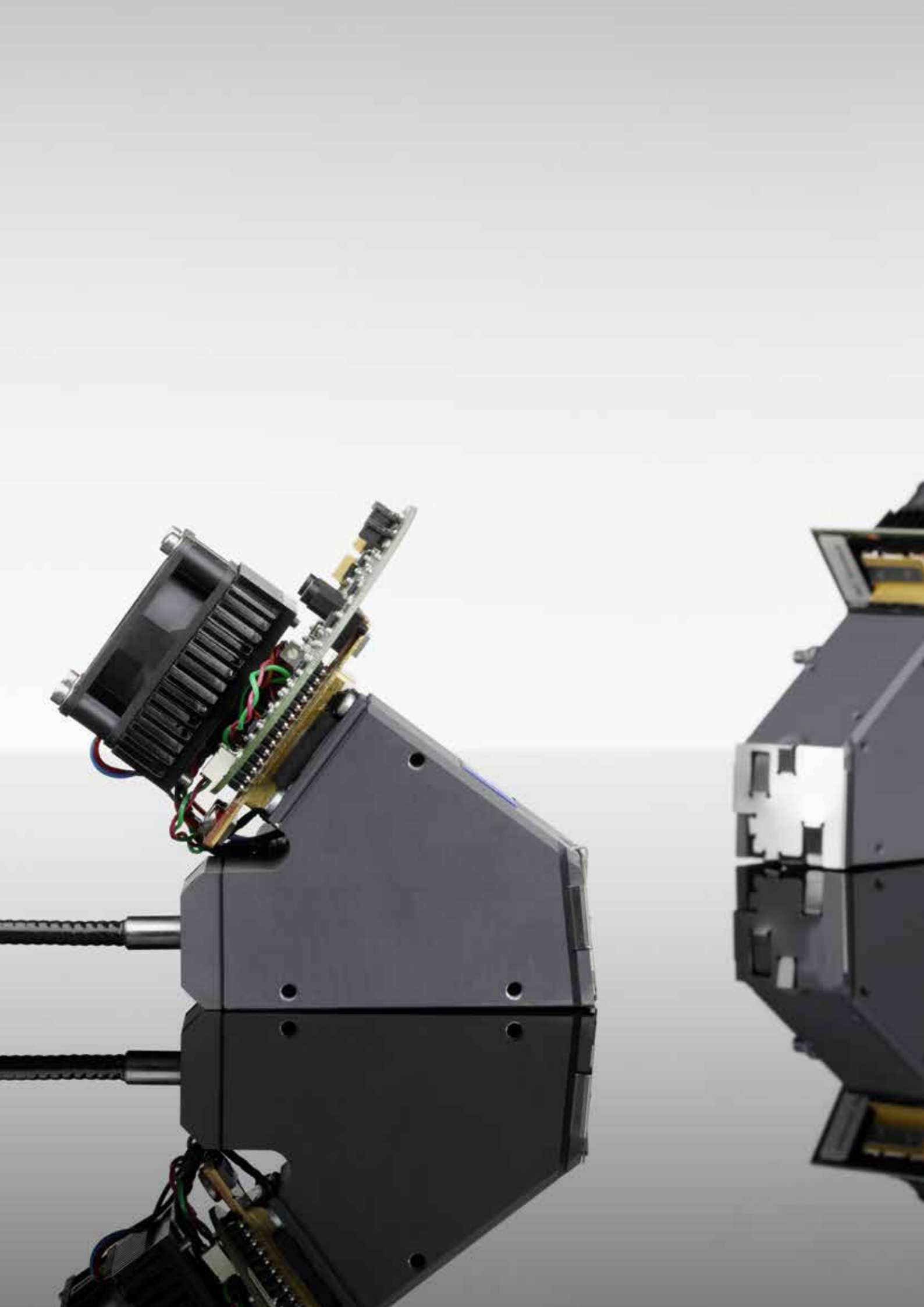

We make it visible.



PGS Family – the NIR specialists

The spectrometers of the PGS family are designed for use in the NIR. InGaAs (indium-gallium-arsenide) is used as a detector material in this wavelength range. The special combination of aspheric collimator and focusing lens allows the use of plane gratings optimized for the NIR, while maintaining good flat field correction of the spectral imaging. Excellent long-term stability is ensured by the permanent connection of all optical components.

Optical components of the PGS family

- blazed plane gratings
- aspheric lenses
- mono-fiber with slit as optical input*
- cooled InGaAs photodiode array as opto-electronic output

Central body

In the PGS family, a special aluminum alloy (coefficient of expansion $\alpha \sim 13 \times 10^{-6}$) is used for the central body. This housing is the carrier of the blazed grating and of the aspheric collimator and focusing lens. The input fiber and the detector are permanently connected to the central body, therefore providing excellent stability.

Gratings

The gratings for the PGS family are mechanically ruled or holographically recorded plane gratings. The maximum efficiency is adapted to the special wavelength range in the NIR. The grating surface with the clear diameter of the lenses is dimensioned so that the light of a fiber with NA of up to 0.37 can be held.

Input fiber

The coupling of light is performed in the standard way via a glass monofiber. These fibers have a diameter of 600 μm and a NA = 0.22. The end of the fiber features a slit with a height of 500 μm (NIR 1.7) or 250 μm (NIR 2.2). The slit heights at the entrance are adapted to the pixel heights of the InGaAs arrays. A cross-sectional conversion similar to the silicon detectors is not necessary.

Detector

For the PGS NIR 1.7 standard InGaAs is used for the wavelength range up to 1700 nm. Detectors with 256 or 512 elements are available. To go up to the wavelength range of 2.2 μm the use of Extended InGaAs is necessary.

In the PGS NIR 2.0 and PGS NIR 2.2 detectors with 256 elements are used. For the Extended InGaAs arrays, blocking filter for suppressing the 2nd diffraction order is applied to the array.

The following modules are available:

Module	Order-Nr.	Wavelength range
PGS NIR 1.7-256 UC**	000000-2109-070	960 nm – 1690 nm
PGS NIR 1.7-256	000000-1381-397	960 nm – 1690 nm
PGS NIR 1.7-512	000000-2122-663	960 nm – 1690 nm
PGS NIR 2.0-256	000000-1396-757	1340 nm – 2000 nm
PGS NIR 2.2-256	000000-1332-256	1000 nm – 2150 nm

* except PGS NIR 1.7-256 UC (FSMA-connector)

** UC – uncooled

Technical specifications

		PGS NIR 1.7-256 UC	PGS NIR 1.7-256	PGS NIR 1.7-512	PGS NIR 2.0-256	PGS NIR 2.2-256
Optical entrance	input round	FSMA 905* NA = 0.22 (has to be filled for full specification) mounted in SMA-coupling	Fiber consisting of Infrasil-quartz glass* Diameter: 0.6 mm Length: 300 mm NA = 0.22 (has to be filled for full specification) mounted in SMA-coupling	Fiber consisting of Infrasil-quartz glass* Diameter: 0.6 mm Length: 300 mm NA = 0.22 (has to be filled for full specification) mounted in SMA-coupling	Fiber consisting of Infrasil-quartz glass* Diameter: 0.6 mm Length: 300 mm NA = 0.22 (has to be filled for full specification) mounted in SMA-coupling	Fiber consisting of Infrasil-quartz glass* Diameter: 0.6 mm Length: 300 mm NA = 0.22 (has to be filled for full specification) mounted in SMA-coupling
	output linear	Slit width: 80 µm	Slit width: 80 µm	Slit width: 80 µm	Slit width: 80 µm	Slit width: 80 µm
Filter		950 nm edge filter	950 nm edge filter	950 nm edge filter	1350 nm edge filter	950 nm edge filter
2nd order filter on detector		—	—	—	—	Yes
Grating		Plane grating, 484 l/mm, blazed for approx. 1.2 µm	Plane grating, 484 l/mm, blazed for approx. 1.2 µm	Plane grating, 484 l/mm, blazed for approx. 1.2 µm	Plane grating, 484 l/mm, blazed for approx. 1.4 µm	Plane grating, 300 l/mm, blazed for approx. 1.4 µm
Diode array		Producer: Hamamatsu Type: G9211-01SPL Number pixels: 256	Producer: Hamamatsu Type: S9203 Number pixels: 256	Producer: Hamamatsu Type: S9204 Number pixels: 512	Producer: Hamamatsu Type: G9206 Number pixels: 256	Producer: Hamamatsu Type: G9206 Number pixels: 256
Spectral range		960 – 1690 nm	960 – 1690 nm	960 – 1690 nm	1340 – 2000 nm	1000 – 2150 nm
Wavelength accuracy		± 1 nm	± 1 nm	± 1 nm	± 1 nm	± 1 nm
Temperature – induced drift (10–40°C)		< 0.012 nm/K	< 0.012 nm/K	< 0.012 nm/K	< 0.012 nm/K	< 0.012 nm/K
Mean spectral pixel pitch		$\Delta\lambda_{\text{Pixel}} \approx 3 \text{ nm}$	$\Delta\lambda_{\text{Pixel}} \approx 3 \text{ nm}$	$\Delta\lambda_{\text{Pixel}} \approx 1.5 \text{ nm}$	$\Delta\lambda_{\text{Pixel}} \approx 3 \text{ nm}$	$\Delta\lambda_{\text{Pixel}} \approx 5 \text{ nm}$
Resolution		$\Delta\lambda_{\text{FWHM}} \approx 8 \text{ nm}$	$\Delta\lambda_{\text{FWHM}} \approx 8 \text{ nm}$	$\Delta\lambda_{\text{FWHM}} \approx 6 \text{ nm}$	$\Delta\lambda_{\text{FWHM}} \approx 8 \text{ nm}$	$\Delta\lambda_{\text{FWHM}} \approx 16 \text{ nm}$
Straylight		≤ 0.1 % as transmission of 10 mm water at 1405 nm (exposure from halogen lamp)	≤ 0.1 % as transmission of 10 mm water at 1405 nm (exposure from halogen lamp)	≤ 0.1 % as transmission of 10 mm water at 1405 nm (exposure from halogen lamp)	≤ 0.1 % as transmission of 10 mm water at 1405 nm (exposure from halogen lamp)	≤ 0.1 % as transmission of 10 mm water at 1405 nm (exposure from halogen lamp)
Weight		approx. 590 g	approx. 590 g	approx. 590 g	approx. 590 g	approx. 590 g

*optional: with optical fibres or FC receptacle

*optional: FSMA 905 or FC receptacle

*optional: FSMA 905 or FC receptacle

*optional: FSMA 905 or FC receptacle

*optional: FSMA 905 or FC receptacle

Dimensional drawings

PGS NIR 1.7-512

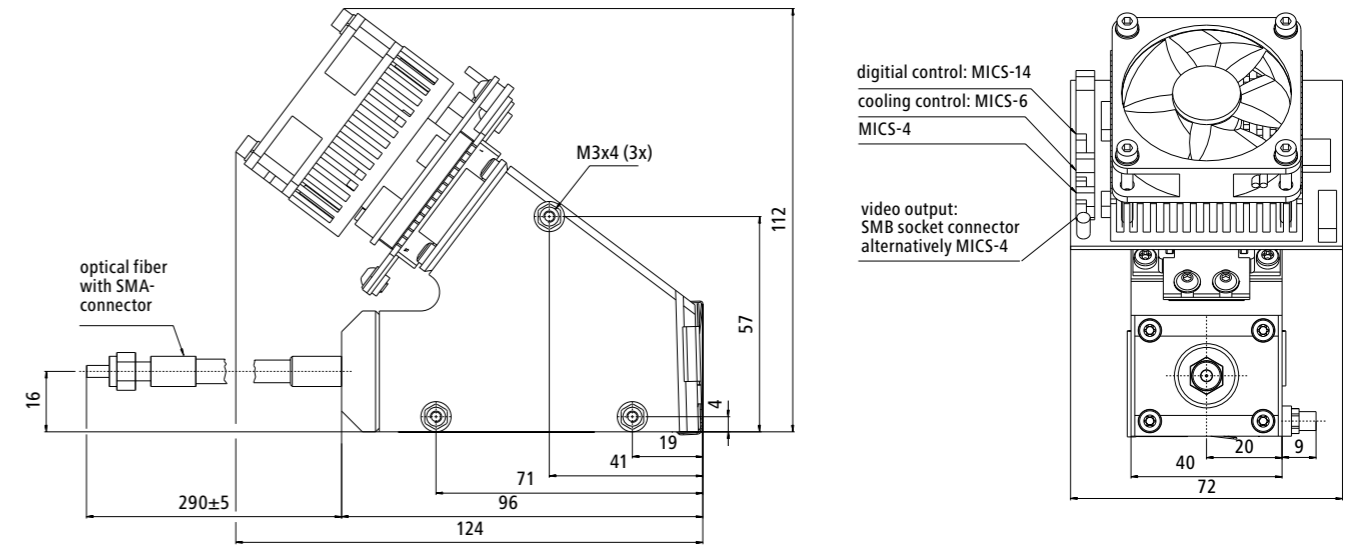

PGS NIR 1.7-256 UC

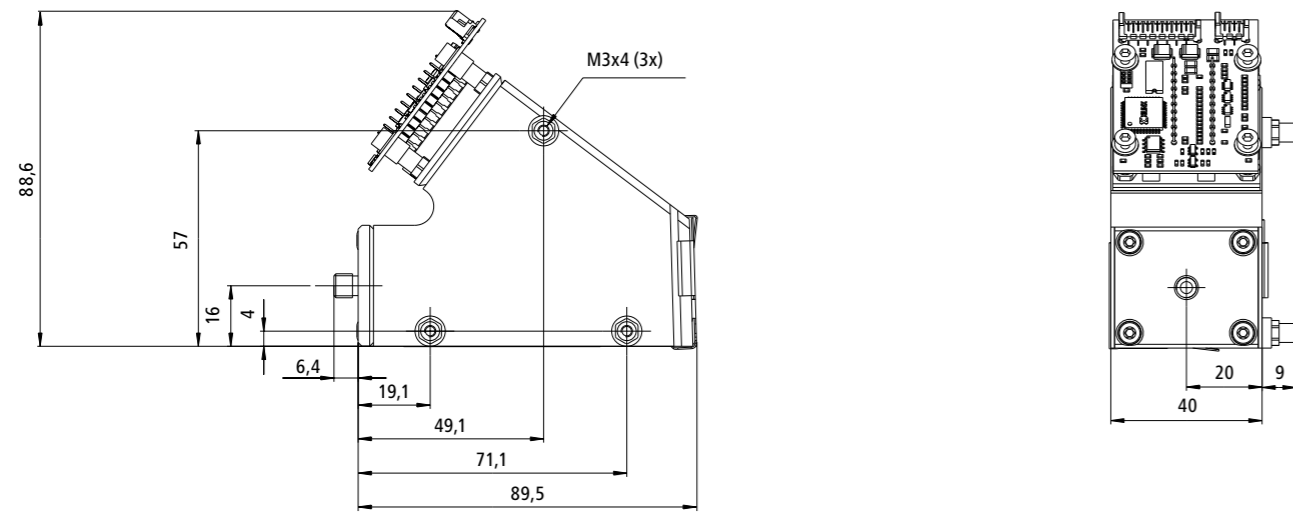

PGS NIR 2.0-256

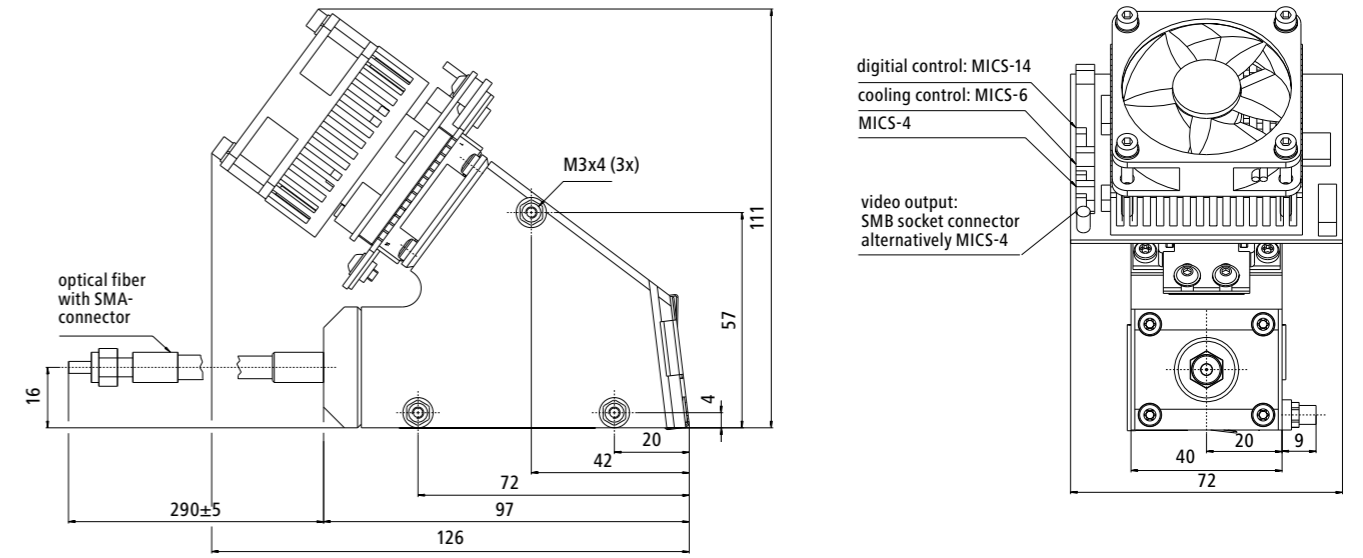

PGS NIR 1.7-256

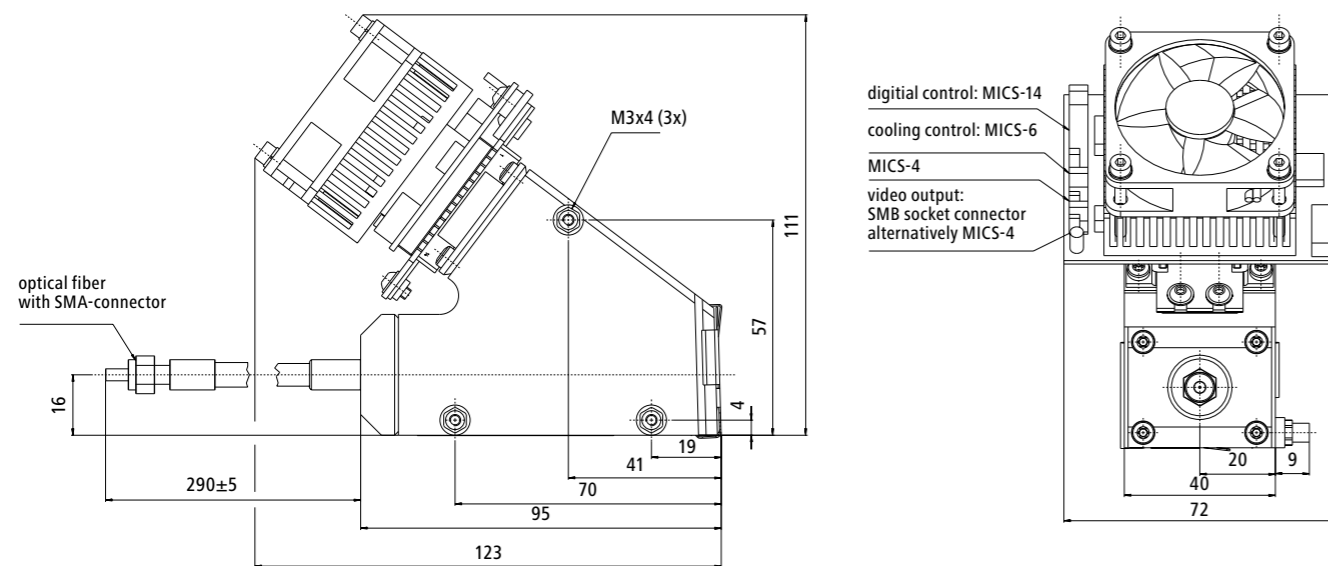

PGS NIR 2.2-256

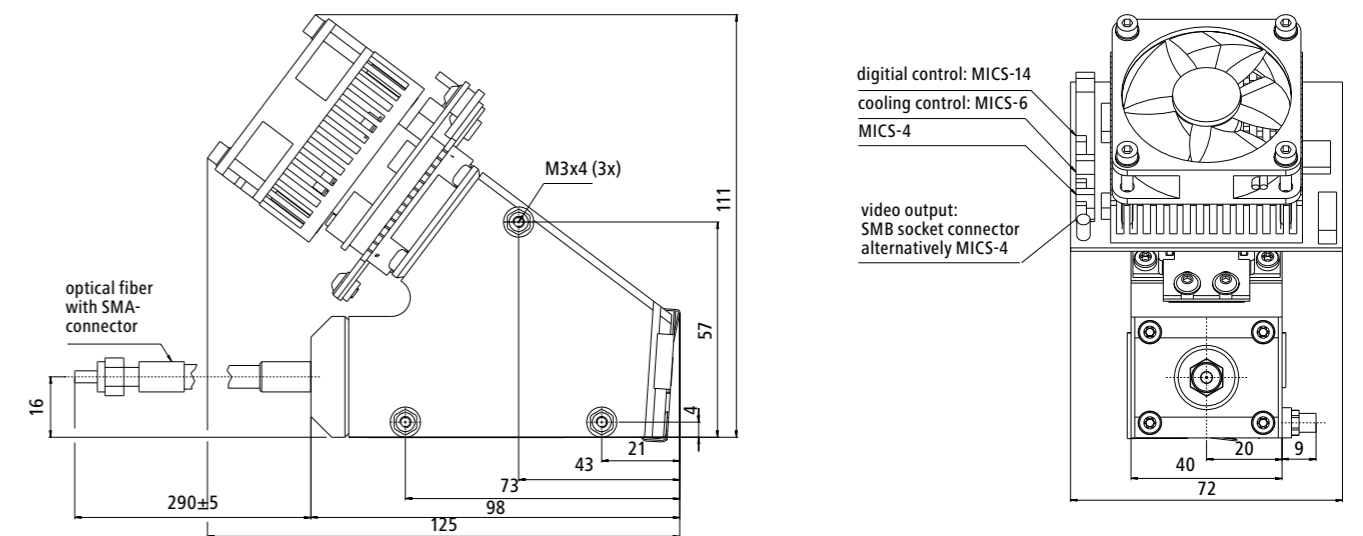

Technical specifications

Detector	PGS NIR 1.7-256 UC	PGS NIR 1.7-256	PGS NIR 1.7-512	PGS NIR 2.0-256	PGS NIR 2.2-256
Producer	Hamamatsu	Hamamatsu	Hamamatsu	Hamamatsu	Hamamatsu
Typ	Multiplexed InGaAs G9211-01SP	Multiplexed InGaAs G9203	Multiplexed InGaAs G9204	Multiplexed InGaAs G9206*	Multiplexed InGaAs G9206*
Number of pixels	256	256	512	256	256
Dimensions of pixels	50 x 250 µm	50 x 500 µm	25 x 500 µm	50 x 250 µm	50 x 250 µm

* According to manufacturer specification up to 5 defect pixels are allowed.

Preamplifier

Output	differential output
Output voltage range	ca. ± 4 V
Rise time	40 V/µs differential
Clock-Rate	80 KHz up to 4 MHz
Read out pixel rate	10 – 500 kPixel/s
Power consumption	650 mW incl. diode array (without cooling)

System data

Realised with	15-Bit-AD-conversion Clock-Rate 80 KHz
Noise	typ. < 4 count standard deviation of dark signal
Dynamic range	≥ 13 Bit

Carl Zeiss Spectroscopy GmbH

Carl-Zeiss-Promenade 10
07745 Jena, Germany

Office: + 49 3641 64-2838
Fax: + 49 3641 64-2485

Email: info.spectroscopy@zeiss.com
www.zeiss.com/spectroscopy

