

datasheet

pco.horizon 9.1 bi TDI CLHS

state-of-the-art in line scan imaging

TDI time delay integration

UV ultraviolet*

resolution
9K

pixel size
5.0 μm x 5.0 μm

interface
CLHS FOL



2 photosensitive bands
p1: 9072 pixels x 256 stages
p2: 9072 pixels x 32 stages

temperature-stabilized
image sensor

max. line frequency
608 kHz

ultraviolet variant
available*

back illuminated CMOS

technical data

| image sensor | | |
|-------------------------------------|--|---|
| | 40G variant | 100G variant |
| sensor technology | back illuminated CMOS time delay integration (bi CMOS TDI) | |
| color type | monochrome | |
| resolution (horizontal × vertical) | 1 photosensitive band 9072 px × 256 stages | 2 photosensitive bands p1: 9072 px × 256 stages p2: 9072 px × 32 stages |
| sensor size (horizontal × vertical) | 45.36 mm × 1.28 mm | p1: 45.36 mm × 1.28 mm p2: 45.36 mm × 0.16 mm |
| sensor diagonal | 45.38 mm | p1: 45.38 mm p2: 45.36 mm |
| pixel size (horizontal × vertical) | 5.0 μm × 5.0 μm | |
| shutter mode | global shutter (GS) | |
| peak quantum efficiency | 82 % @ 550 nm 72 % @ 440 nm (UV variant) | |
| spectral range | 200 nm - 1100 nm | |
| dark current (typ.) | 8000 e ⁻ /pixel/s @ +30 °C sensor temperature | |
| fullwell capacity | 15 000 e ⁻ | |
| readout noise (typ.) | | |
| @ 10 bit single band | 11 e ⁻ | |
| @ 12 bit single band | 6 e ⁻ | |
| dynamic range (intra-scene) | | |
| @ 10 bit single band | 62.7 dB | |
| @ 12 bit single band | 68.0 dB | |

quantum efficiency

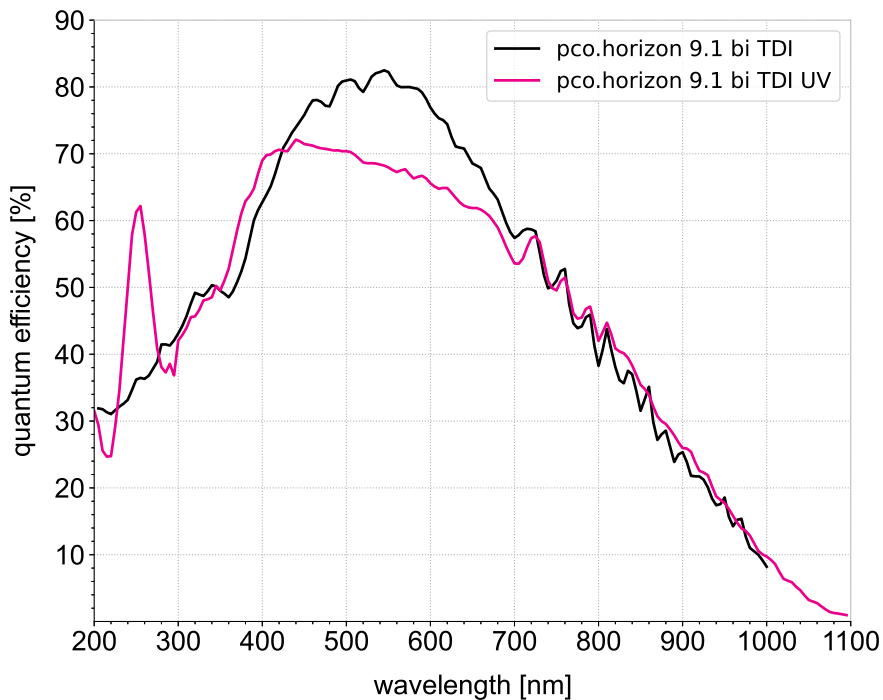

| camera | | |
|---|-------------|--|
| | 40G variant | 100G variant |
| max. line frequency | | |
| @ 8 bit single band | 540 kHz | 608 kHz |
| @ 10 bit single band | 432 kHz | 608 kHz |
| @ 12 bit single band | 300 kHz | 300 kHz |
| dynamic range A/D | | 8 bit 10 bit 12 bit |
| max. data rate | 40 Gbps | 75 Gbps |
| photo response non-uniformity (PRNU) | | < 1 % |
| cooling method | | forced air liquid cooling system integration via defined thermal interface |
| trigger input signals | | line trigger |
| status output signals | | exposure, busy |
| input / output signal connector | | Hirose 12-pin circular |
| meta data | | available |
| data interface | | Camera Link HS FOL |

special features

The pco.horizon 9.1 bi TDI CLHS is a line scan camera. It incorporates a back illuminated, charge-domain CMOS image sensor with built-in Time Delay Integration (TDI).

The sensor features a pixel size of 5 µm, an effective resolution of 9072 pixels, and is equipped with two photosensitive bands, 256 stages and 32 stages respectively. By maximizing the sensitivity from ultraviolet to near infrared, it is designed to meet the needs of high-speed and low-light applications.

The camera is available in two spectral variants—a standard model with a broad spectral response and a UV model dedicated to DUV applications. In addition, both variants offer selectable options for frame rate, cooling method, and interface speed, allowing the configuration to be adapted to a wide range of applications.

The camera's data output impresses with its reliability, speed and high bandwidth due to utilizing the standard protocol of Camera Link HS with a FOL cable connection.

general

| | |
|---|--|
| power supply | 24 VDC ($\pm 10\%$) (tbd) (Hirose 12-pin circular) |
| power consumption | max. 55 W (tbd) |
| weight | 0.8 kg (tbd) |
| dimensions (height x width x length¹) | 115.5 mm x 79.5 mm x 61.1 mm |
| operating temperature range | +10 °C to +40 °C |
| storage temperature range | -10 °C to +60 °C |
| humidity range (non-condensing) | 10 % to 80 % (recommended < 65 %) |
| certifications | CE, FCC, UKCA |

¹ This value refers to the length including the camera flange. The length depends on the selected cooling method.

optical interface

| | |
|--|--|
| direct mounting distance (no camera flange) | 4.3 mm $\pm 10\%$ |
| lens mounting | M58 x 0.75 (flange focal distance 12.3 mm) |

Configure your optical setup with our **MachVis Lens Selector** online tool.

dimensions

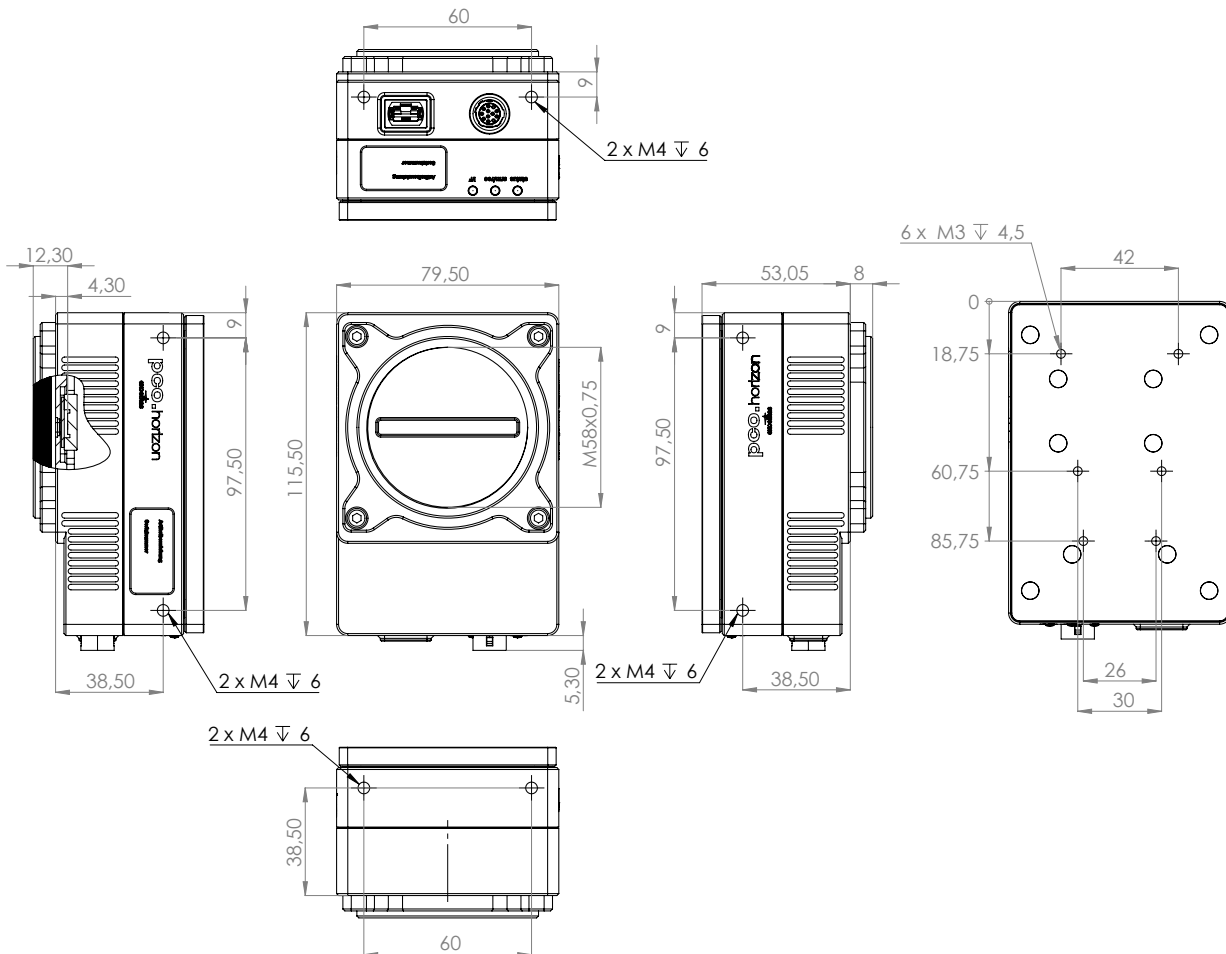

outlines of pco.horizon 9.1 bi TDI CLHS with camera flange (all dimensions given in mm)

thermal design options

The pco.horizon 9.1 bi TDI CLHS features sophisticated thermal management, based on a heatpipe design. It is engineered to offer several options for cooling, such as forced air, liquid cooling, or individual system integration. All while having a compact form and space-saving dimensions.

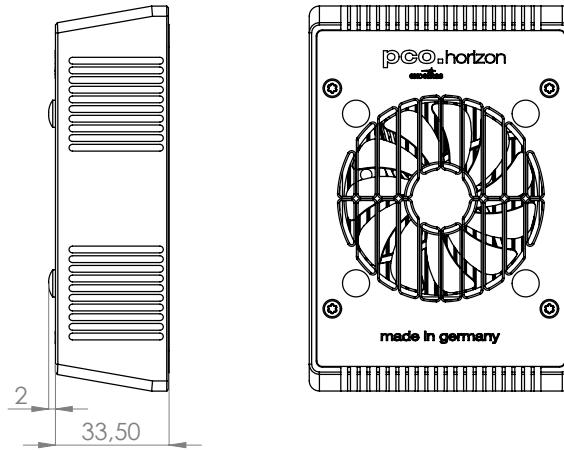

air cooling module for pco.horizon 9.1 bi TDI CLHS (all dimensions given in mm)

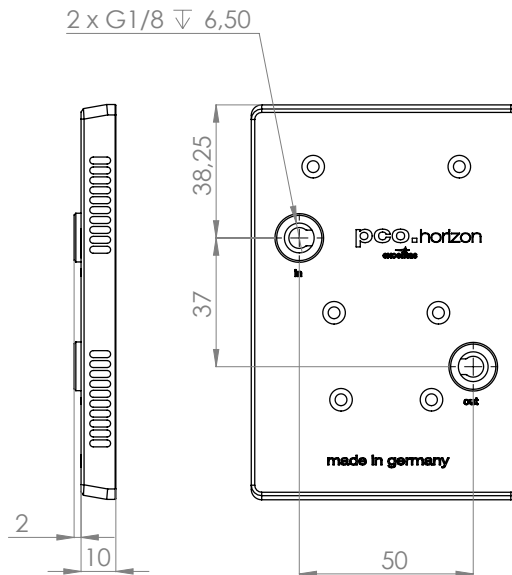

liquid cooling module for pco.horizon 9.1 bi TDI CLHS (all dimensions given in mm)

software

Your first choice is pco.camware:

Our main camera control software enables control of most camera settings and facilitates image acquisition and storage.

You can customize it exactly to your needs using different layouts, styles and features.

You prefer to use a different software:

Our cameras integrate with a range of third-party software applications.

In microscopy we offer dedicated support for μ Manager, while ensuring compatibility with other software maintained by their providers.

You want to create your own application:

We feature a wide range of software development kits (SDK) for various programming languages, such as C++, Python, C#, LabVIEW, Matlab, and Java.

If you are looking for more general SDKs, we present pco.sdk and pco.recorder, our low-level SDKs with C interface.

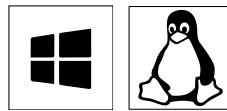
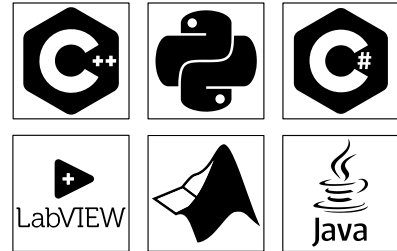

Our software is available for Windows and Linux platforms.

Visit our **website** for detailed information, installation guidance, and Github projects.

areas of application

digital pathology | flat panel inspection | fluorescence imaging | gene sequencing | industrial quality inspection | machine vision | material testing | optical inspection | PCB and electronics inspection | wafer inspection

ordering information

| | | |
|--|-------------|---|
| pco.horizon 9.1 bi TDI CLHS 40G | 85108000900 | camera system, 9072 pixels, 1 photosensitive band, monochrome, time delay integration, global shutter, CLHS interface, air/liquid/no/passive cooling |
| pco.horizon 9.1 bi TDI UV CLHS 40G | 85108000901 | camera system, 9072 pixels, 1 photosensitive band, monochrome, time delay integration, global shutter, UV-enhanced sensor, CLHS interface, air/liquid/no/passive cooling |
| pco.horizon 9.1 bi TDI CLHS 100G | 85108000902 | camera system, 9072 pixels, 2 photosensitive bands, monochrome, time delay integration, global shutter, CLHS interface, air/liquid/no/passive cooling |
| pco.horizon 9.1 bi TDI UV CLHS 100G | 85108000903 | camera system, 9072 pixels, 2 photosensitive bands, monochrome, time delay integration, global shutter, UV-enhanced sensor, CLHS interface, air/liquid/no/passive cooling |

pco.[®]

address: Excelitas PCO GmbH
Donaupark 11
93309 Kelheim, Germany

phone: (+49) 9441-2005-0
(+1) 866-662-6653
(+86) 0512-6763-4643

mail: pco@excelitas.com

web: www.excelitas.com/pco



excelitas.com

excelitas[®]